



Cambridge International AS & A Level

DESIGN AND TECHNOLOGY

9705/32

Paper 3 Written

May/June 2023

MARK SCHEME

Maximum Mark: 120

Published

This mark scheme is published as an aid to teachers and candidates, to indicate the requirements of the examination. It shows the basis on which Examiners were instructed to award marks. It does not indicate the details of the discussions that took place at an Examiners' meeting before marking began, which would have considered the acceptability of alternative answers.

Mark schemes should be read in conjunction with the question paper and the Principal Examiner Report for Teachers.

Cambridge International will not enter into discussions about these mark schemes.

Cambridge International is publishing the mark schemes for the May/June 2023 series for most Cambridge IGCSE, Cambridge International A and AS Level and Cambridge Pre-U components, and some Cambridge O Level components.

This document consists of **16** printed pages.

PUBLISHED**Generic Marking Principles**

These general marking principles must be applied by all examiners when marking candidate answers. They should be applied alongside the specific content of the mark scheme or generic level descriptors for a question. Each question paper and mark scheme will also comply with these marking principles.

GENERIC MARKING PRINCIPLE 1:

Marks must be awarded in line with:

- the specific content of the mark scheme or the generic level descriptors for the question
- the specific skills defined in the mark scheme or in the generic level descriptors for the question
- the standard of response required by a candidate as exemplified by the standardisation scripts.

GENERIC MARKING PRINCIPLE 2:

Marks awarded are always **whole marks** (not half marks, or other fractions).

GENERIC MARKING PRINCIPLE 3:

Marks must be awarded **positively**:

- marks are awarded for correct/valid answers, as defined in the mark scheme. However, credit is given for valid answers which go beyond the scope of the syllabus and mark scheme, referring to your Team Leader as appropriate
- marks are awarded when candidates clearly demonstrate what they know and can do
- marks are not deducted for errors
- marks are not deducted for omissions
- answers should only be judged on the quality of spelling, punctuation and grammar when these features are specifically assessed by the question as indicated by the mark scheme. The meaning, however, should be unambiguous.

GENERIC MARKING PRINCIPLE 4:

Rules must be applied consistently, e.g. in situations where candidates have not followed instructions or in the application of generic level descriptors.

GENERIC MARKING PRINCIPLE 5:

Marks should be awarded using the full range of marks defined in the mark scheme for the question (however; the use of the full mark range may be limited according to the quality of the candidate responses seen).

GENERIC MARKING PRINCIPLE 6:

Marks awarded are based solely on the requirements as defined in the mark scheme. Marks should not be awarded with grade thresholds or grade descriptors in mind.

PUBLISHED

| Question | Answer | Marks | Guidance |
|--------------------------------|---|----------|---|
| Section A | | | |
| Part A – Product Design | | | |
| 1(a) | suitable material: – aluminium alloy, brass, mild steel – hardwood, e.g. beech – abs, polyamide 1 reasons: – will hold appropriate weight – rigid, does not shear easily – easy to manufacture 1 x 2 | 3 | <i>Accept any other suitable material or any other reason appropriate to material choice</i> |
| 1(b) | quality of description: – fully detailed all/most stages – some detail, – quality of sketches 4–7 0–3 up to 2 | 9 | <i>Dependant on material chosen.</i> <i>Shape cut and finished</i> <i>Heat bent polymer</i> <i>Hole drilled</i> <i>Rod cemented in</i> <i>Metal cut to shape</i> <i>Bent to correct angle</i> <i>Hole drilled and rod brazed (could be brazed or welded to outer surface)</i> <i>Tight grained hardwood could be cut from one piece with grain in correct direction</i> <i>Hole drilled and rod glued in place</i> <i>Finish applied</i> <i>Must show all key stages of manufacture for full marks</i> |

PUBLISHED

| Question | Answer | Marks | Guidance |
|----------|---|----------|---|
| 1(c) | <p>explanation could include:</p> <ul style="list-style-type: none"> – change in process; – change in materials; – use of jigs, formers, moulds; – simplification of design. <p>quality of explanation:</p> <ul style="list-style-type: none"> – logical, structured 4–6 – limited detail, 0–3 – quality of sketches up to 2 | 8 | <p><i>Would expect appropriate polymer and injection moulding or 3D printing</i></p> <p><i>Full details of mould required for injection moulding</i></p> <p><i>Full details of CAD drawing and set up for 3D printing</i></p> |

| Question | Answer | Marks | Guidance |
|----------|--|-----------|--|
| 2 | <p>examination of issues</p> <ul style="list-style-type: none"> – wide range of relevant issues 4–8 – limited range 0–3 <p>quality of explanation</p> <ul style="list-style-type: none"> – logical, structured 4–8 – limited detail, 0–3 <p>supporting examples / evidence 4</p> | 20 | <p>Discussion could include:</p> <ul style="list-style-type: none"> – explore a wider range of ideas and possibilities other than 2D drawing – functions/proportions can be tested – hands on evaluation – range of modelling, 2D, 3D, CAD <p>examples / evidence could be:</p> <ul style="list-style-type: none"> – specific modelling examples, – specific modelling methods <p><i>Full understanding of the importance of the range of modelling methods to developing products for full marks. Reasoning and the value of different methods employed at different stages in the development of products.</i></p> |

PUBLISHED

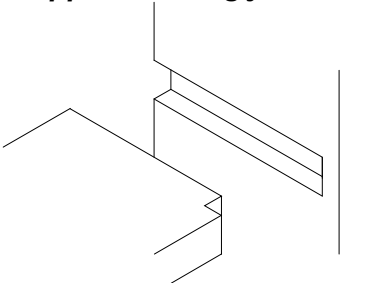
| Question | Answer | Marks | Guidance |
|----------|--|-----------|---|
| 3(a) | description of process – fully detailed, all/most stages 3–5 – some detail, 0–2 – quality of sketches up to 2 2 × 7 | 14 | <p>Etching</p> <ul style="list-style-type: none"> – clean and dry the copper blank – apply star design with resist (permanent ink) and on sides and back. Etching resist tape can be used – prepare etching acid (ferric chloride) – carefully immerse badge in etching acid – carefully agitate acid 10 minute intervals – remove badge and check suitable etch depth is achieved – carefully wash, then polish <p>Ensure all correct safety considerations are taken</p> <p>Stopped housing joint</p>  <ul style="list-style-type: none"> – prepare side and shelf – accurately mark out joint – carefully cut recess on side – cut on waste side, mark depth on chisel – cut housing to fit, enabling flush front – router, hand or power could be used with care. |

PUBLISHED

| Question | Answer | Marks | Guidance |
|----------|---|----------|--|
| 3(a) | | | <p>Line bending</p> <ul style="list-style-type: none"> – shape acrylic, – accurately mark the bends with water-based marker – polish edges – prepare former – turn on strip heater – accurately carry out each bend in turn <p>Accept heat in an oven and use of former to produce correct shape</p> <p>Accept any other correct variations or methods.</p> |
| 3(b) | <p>etching</p> <ul style="list-style-type: none"> – complex patterns produced – very quick process – no expensive machinery required <p>stopped housing joint</p> <ul style="list-style-type: none"> – joint is hidden – strong mechanical strength – keeps shelf flat <p>line bending</p> <ul style="list-style-type: none"> – limited cost of equipment – relatively quick process – no finishing required <p style="text-align: right;">2 × 3</p> | 6 | Accept other valid explanations, brief outline points max 3 |

| Question | Answer | Marks | Guidance |
|--------------------------------------|--|-----------|--|
| Part B – Practical Technology | | | |
| 4(a) | <p>Clear comparison of benefits and drawbacks relating to aesthetic and physical properties of materials 5–6</p> <p>Some comparison of benefits and drawbacks relating to aesthetic and physical properties of materials 3–4</p> <p>Limited or no evidence of comparison of benefits and drawbacks relating to aesthetic and physical properties of materials 0–2</p> | 6 | <p>Benefits could be: <i>aesthetics and physical properties</i> wood – natural, attractive grain, easy to construct well designed furniture, stable and robust metal – very sturdy, complex designs can be achieved with casting, bending etc plastic – available in many colours, one piece furniture is possible,</p> <p>Drawbacks could be: <i>aesthetics and physical properties</i> wood – may distort, warp or split, have knots, finish fades/dicolours metal – can look heavy or bulky, often very heavy plastic – can look ‘cheap’ and featureless, can break quite easily</p> |
| 4(b) | <p>Clear comparison of benefits and drawbacks relating to manufacture and cost of materials 8–10</p> <p>Good comparison of benefits and drawbacks relating to manufacture and cost of materials 5–7</p> <p>Some comparison of benefits and drawbacks relating to manufacture and cost of materials 3–4</p> <p>Limited or no evidence of comparison of benefits and drawbacks relating to manufacture and cost of materials 0–2</p> | 10 | <p>Benefits could be: <i>manufacture and cost</i> wood – can be handmade or machine made to high standard, wide range of construction possibilities, can be relatively low-cost products available metal – could be bent, cast, welded, wide range of manufacturing possibilities, moderately low cost plastic – mostly high quantity production methods e.g. injection moulding, mostly low cost</p> <p>Drawbacks could be: <i>manufacture and cost</i> wood – some hardwoods very expensive metal – cast products sometimes heavy and lacking features, plastic – quantity production methods limits features on the furniture</p> |

PUBLISHED

| Question | Answer | Marks | Guidance |
|----------|--|-------|--|
| 4(c) | <p>Good comparison of benefits and drawbacks relating to maintenance 3–4</p> <p>Limited or no evidence of comparison of benefits and drawbacks relating to maintenance 0–2</p> | 4 | <p>Benefits could be: <i>maintenance</i> wood – some hardwoods are very long lasting or require minimal application of finish. metal – Aluminium, stainless steel, very long lasting. plastic – occasional cleaning required</p> <p>Drawbacks could be: <i>maintenance</i> wood – may distort, warp or split, have knots, finish fades/dicolours metal – iron, steel furniture often requires regular additional finish plastic – some plastics degrade or discolour in sunlight</p> |

| Question | Answer | Marks | Guidance |
|----------|---|-------|---|
| 5 | <p>examination of issues</p> <ul style="list-style-type: none"> – wide range of relevant issues 4–8 – limited range 0–3 <p>quality of explanation</p> <ul style="list-style-type: none"> – logical, structured 4–8 – limited detail, 0–3 <p>supporting examples / evidence 4</p> <p>quality of explanation</p> <ul style="list-style-type: none"> – logical, structured 3–4 – limited detail, 0–2 <p>supporting examples / evidence 2</p> | 20 | <p>Discussion could include:</p> <ul style="list-style-type: none"> – design/fashion trends – new materials/technology available – customer demand – environmental considerations <p>examples / evidence could be:</p> <ul style="list-style-type: none"> – specific products – specific company practice |

PUBLISHED

| Question | Answer | Marks | Guidance |
|----------|--|-------------------------------------|---|
| 6(a)(i) | Full and clear description of use of photoelasticity Partial description of use of elasticity Partial description of elasticity No creditable response | 3 2 1 0 | 3 Photoelasticity refers to the changes in the optical properties of a material under mechanical deformation. It is used to determine the stress distribution in a material and indicates potential stress areas. |
| 6(a)(ii) | Full and clear description of use of strain gauge Partial description of use of strain gauge Partial description of strain gauge No creditable response | 3 2 1 0 | 3 Strain gauge is a sensor identifying deformation that results in a change in resistance e.g. bridge/building structural checks |
| 6(b)(i) | material could be: Mild steel, medium carbon steel, stainless steel | 1 | 1 |
| 6(b)(ii) | Product could be: Transmission shaft, screwdriver shaft clear description of torsional suitability Partial description of torsional suitability No creditable response | 1 2 1 0 | 3 |
| 6(c) | Ways identified quality of explanation – clear, logical, structured – not all ways clearly explained – limited detail, – no creditable response | 3 × 1 5–7 3–4 1–2 0 | 10 Ways could be: – design feasibility checks – material checks – quality control checks during manufacture – prototype testing – checks against standards |

PUBLISHED

| Question | Answer | Marks | Guidance |
|----------------------------------|---|-----------|---|
| Part C – Graphic Products | | | |
| 7(a)(i) | See App1 fully correct plan 2 fully correct elevation 2 scale 1 correct projection 1 | 6 | |
| 7(a)(ii) | correct position 1 accuracy of shape 2 line quality 1 | 4 | |
| 7(b) | examination of issues – wide range of relevant issues 2–4 – limited range 0–1 quality of explanation – logical, structured 2–4 – limited detail, 0–1 supporting examples / evidence 2 | 10 | Discussion could include: – clarity – consistency – accuracy examples / evidence could be: – engineered/architectural products – multi national collaboration |

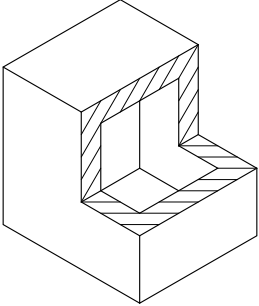
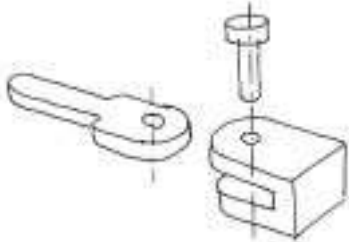
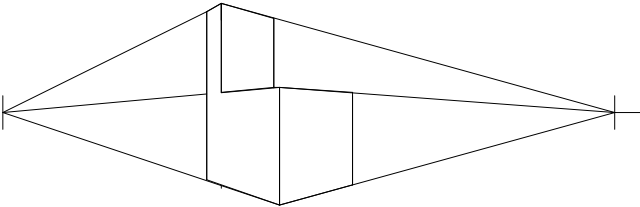
| Question | Answer | Marks | Guidance |
|------------------------|---|------------------------------|---|
| 8(a)(i),(ii), (iii) | quality of explanation: – logical, structured, well communicated – limited detail, reasonable communication – no creditable response | 4–5 1–3 0 3 × 5 | <div style="text-align: center;">  </div> <p>Cut-away drawings show the construction and internal workings of an object or structure. Used by engineers and architects and product catalogues</p> <div style="text-align: center;">  </div> <p>Exploded drawings show how component parts in a product relate. Used for assembly and identification</p> <div style="text-align: center;">  </div> <p>2-point perspective provides a more realistic view of a product or object. Can be viewed from above, on or below horizon line. Used a lot in architecture</p> |

PUBLISHED

| Question | Answer | Marks | Guidance |
|----------|--|----------|---|
| 8(b) | quality of explanation: – logical, structured, detailed 4–5 – limited response, some detail, 1–3 – no creditable response 0 | 5 | Benefits could be: – speed – wide range of ideas can be generated – increase creative options, no fear of error – easily modified/discarded – limited equipment required |

| Question | Answer | Marks | Guidance |
|----------|--|-----------|---|
| 9(a) | quality of description: – correct mechanism, well communicated 3–4 – some aspects correct 1–2 – no creditable response 0 3 × 4 | 12 | A thread B gears C cam Accept any other correct mechanism |
| 9(b) | See App 2 Accurate linkage drawing 2 Arc division 2 Linear location 2 Loci accuracy 2 | 8 | |

PUBLISHED

| Question | Answer | Marks | Guidance |
|------------------|---|-----------|----------|
| Section B | | | |
| 10, 11, 12 | <p>Analysis Analysis of the given situation/problem. [0–5]</p> <p>Specification Detailed written specification of the design requirements. At least five specification points other than those given in the question. [0–5]</p> <p>Exploration Bold sketches and brief notes to show exploration of ideas for a design solution, with reasons for selection. range of ideas [0–5] annotation related to specification [0–5] marketability, innovation [0–5] evaluation of ideas, selection leading to development [0–5] communication [0–5]</p> <p>Development Bold sketches and notes showing the development, reasoning and composition of ideas into a single design proposal. Details of materials, constructional and other relevant technical details. development [0–5] reasoning [0–5] materials [0–3] constructional detail [0–7] communication [0–5]</p> <p>Proposed solution Produce drawing/s of an appropriate kind to show the complete solution. proposed solution [0–10] details/dimensions [0–5]</p> <p>Evaluation Written evaluation of the final design solution. [0–5]</p> | 80 | |

App. 1 Q7 (a)

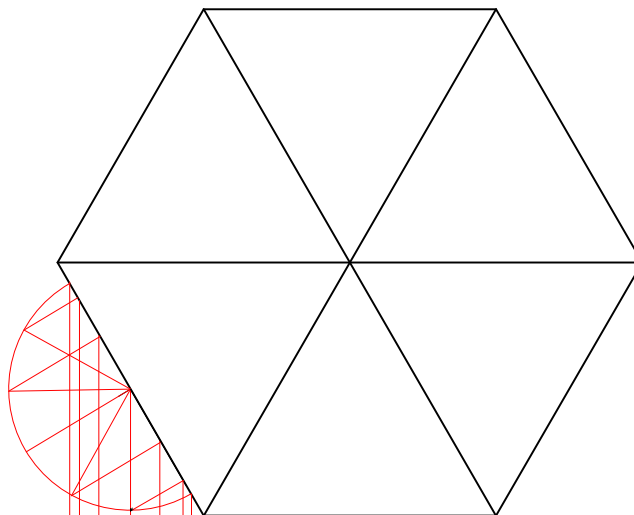

App. 2 Q9 (b)

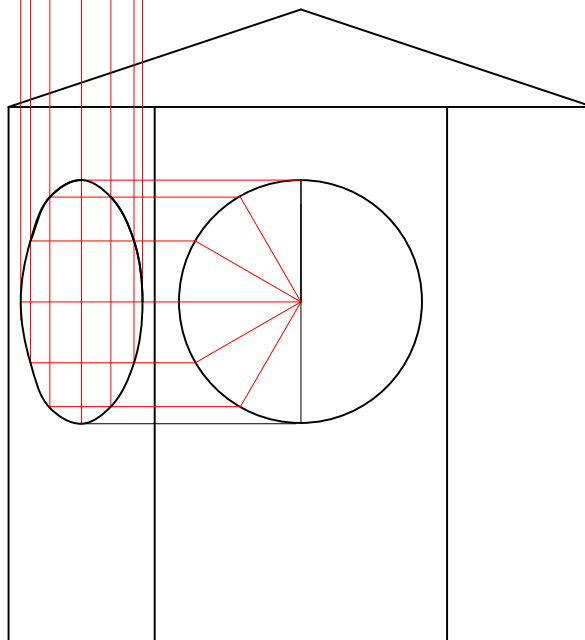

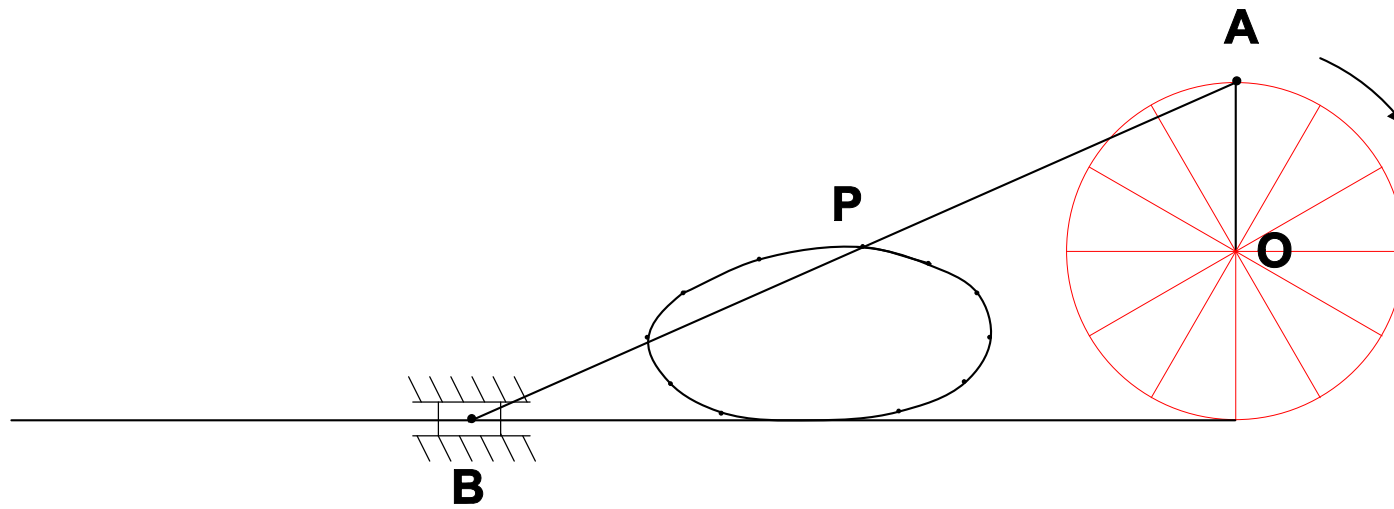

| | |
|--------------------------|---|
| Accurate linkage drawing | 2 |
| Arc division | 2 |
| Linear location | 2 |
| Loci accuracy | 2 |